

OBJECTIVE: Dust control and conveyor belt cleaning at various locations along conveyor line.

SOLUTION: Apply fine spray to suppress airborne dust particles, coarse spray to prevent dust particles from becoming airborne, and more concentrated spray at conveyor return surfaces for cleaning.

EQUIPMENT:

- Transfer points: 1/4LN Hollow Cone hydraulic atomizing nozzles if no compressed air is available or if area is not enclosed. 1/4J air atomizing spray nozzles if compressed air is available and area is enclosed.
- Moving material: Appropriately sized VeeJet® flat spray hydraulically atomizing spray nozzles spraying downward onto material.
- Cleaning: Appropriately sized VeeJet fan pattern or FlatJet high impact flat spray nozzles focused on belt return surfaces.

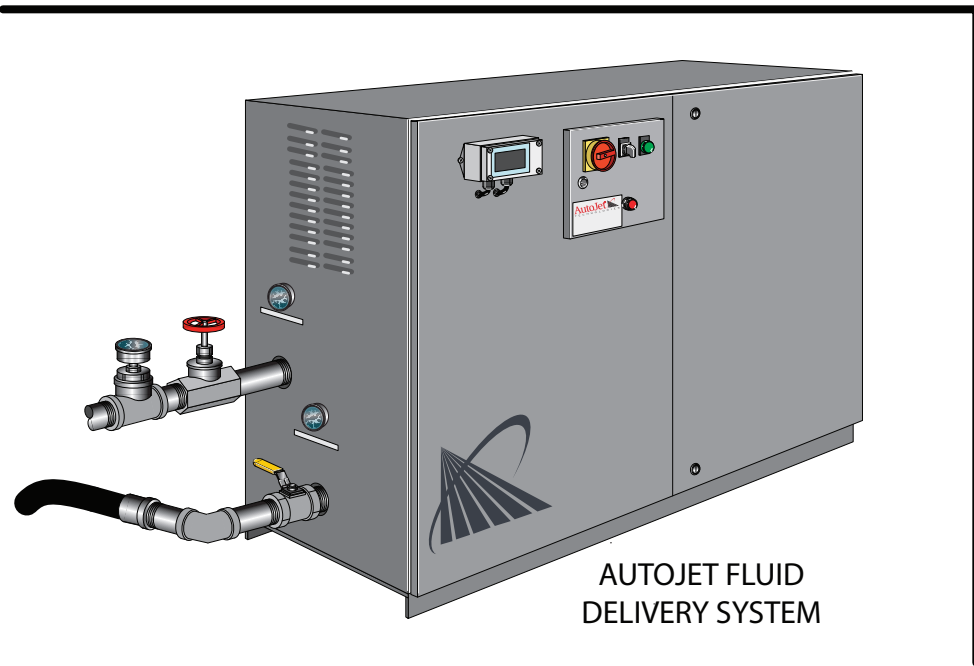
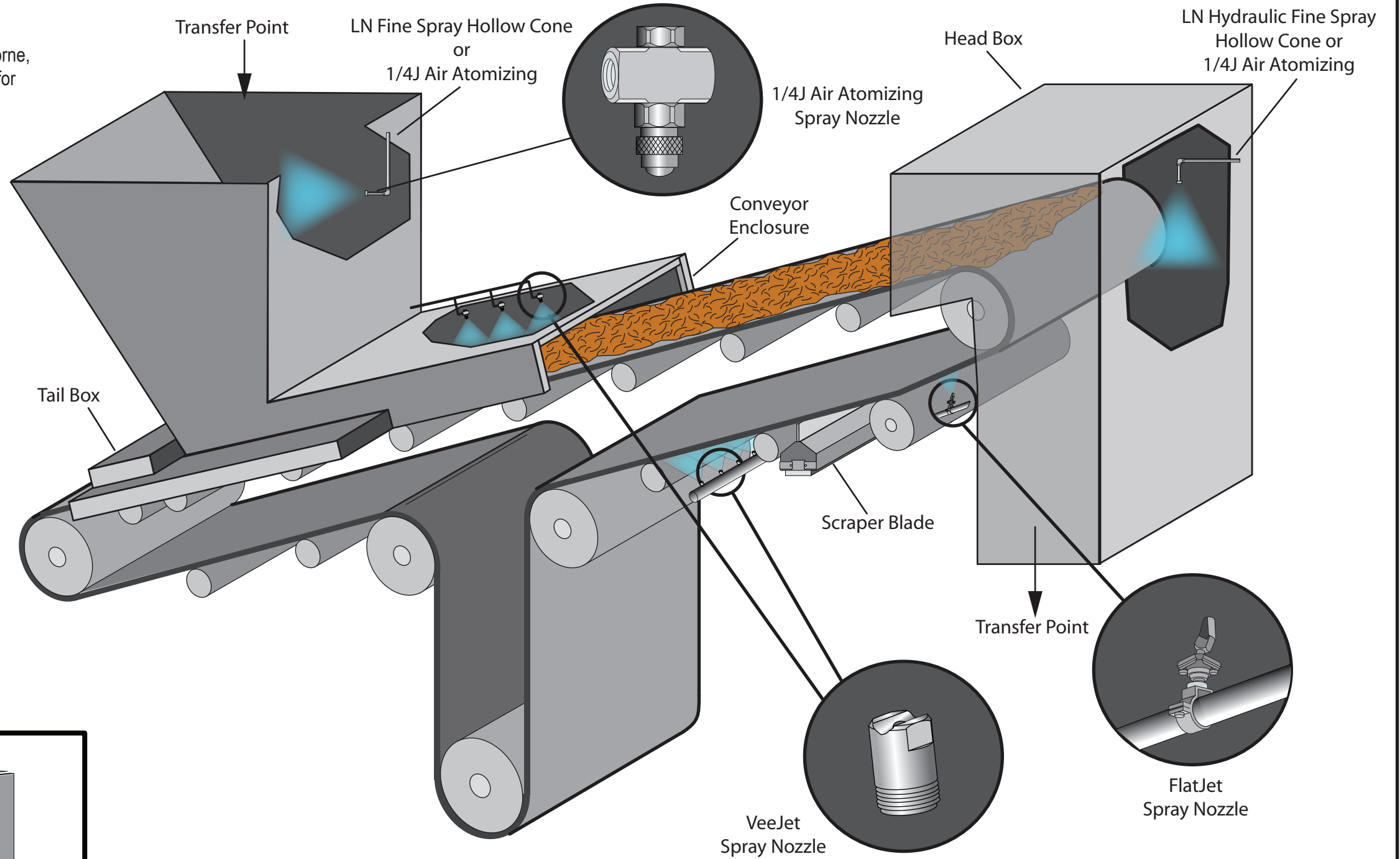

DESCRIPTION:
DUST CONTROL AND CONVEYOR BELT CLEANING AT VARIOUS LOCATIONS ALONG CONVEYOR LINE



Rev. No.
 Ref.

Application Drawing No.
63951-2